

- 1 THE NOTCHED EDGES AND POST TIPS WILL NOT BE PLATED.
- 2 0.00254-0.00508 [.000100-.000200] MATTE TIN OVER 0.00127 [.000050] MIN NICKEL.

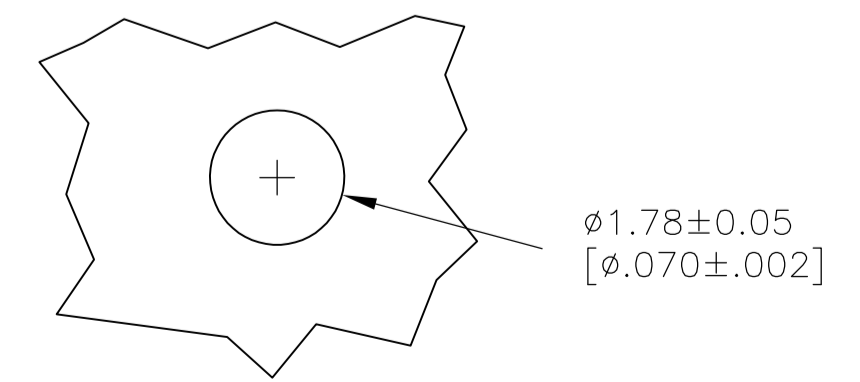
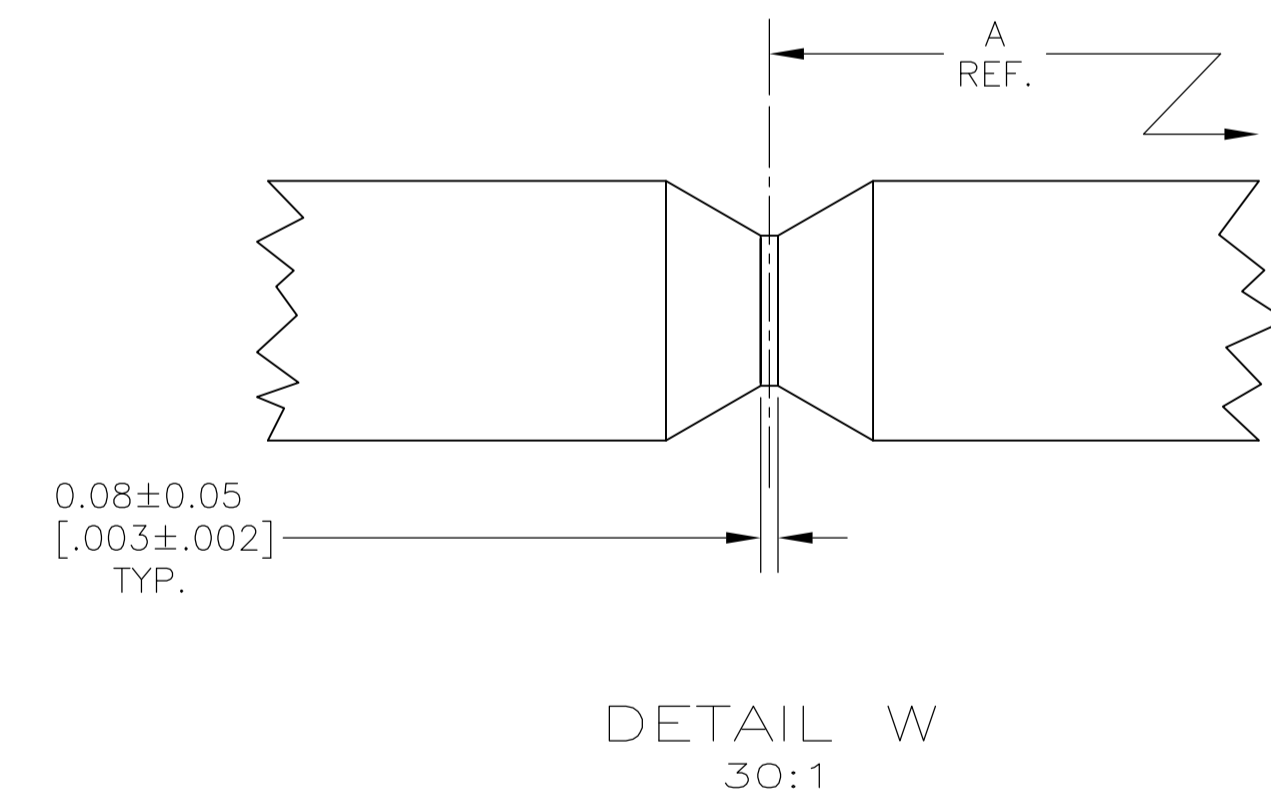
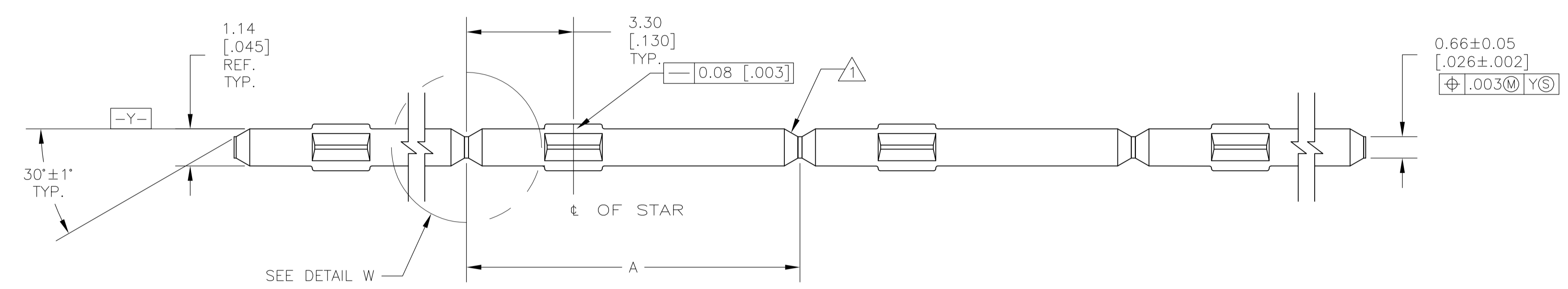

25.40	[1.000]	6-147436-1
25.15	[.990]	6-147436-0
24.89	[.980]	5-147436-9
24.64	[.970]	5-147436-8
24.38	[.960]	5-147436-7
24.13	[.950]	5-147436-6
23.88	[.940]	5-147436-5
23.62	[.930]	5-147436-4
23.37	[.920]	5-147436-3
23.11	[.910]	5-147436-2
22.86	[.900]	5-147436-1
22.61	[.890]	5-147436-0
22.35	[.880]	4-147436-9
22.10	[.870]	4-147436-8
21.84	[.860]	4-147436-7
21.59	[.850]	4-147436-6
21.34	[.840]	4-147436-5
21.08	[.830]	4-147436-4
20.83	[.820]	4-147436-3
20.57	[.810]	4-147436-2
20.32	[.800]	4-147436-1
20.07	[.790]	4-147436-0
19.81	[.780]	3-147436-9
19.56	[.770]	3-147436-8
19.30	[.760]	3-147436-7
19.05	[.750]	3-147436-6
18.80	[.740]	3-147436-5
18.54	[.730]	3-147436-4
18.28	[.720]	3-147436-3
18.03	[.710]	3-147436-2
17.78	[.700]	3-147436-1
17.53	[.690]	3-147436-0
17.27	[.680]	2-147436-9
17.02	[.670]	2-147436-8
16.76	[.660]	2-147436-7
16.51	[.650]	2-147436-6
16.26	[.640]	2-147436-5
16.00	[.630]	2-147436-4
15.75	[.620]	2-147436-3
15.49	[.610]	2-147436-2
15.24	[.600]	2-147436-1
14.99	[.590]	2-147436-0
14.73	[.580]	1-147436-9
14.48	[.570]	1-147436-8
14.22	[.560]	1-147436-7
13.97	[.550]	1-147436-6
13.72	[.540]	1-147436-5
13.46	[.530]	1-147436-4
13.21	[.520]	1-147436-3
12.95	[.510]	1-147436-2
12.70	[.500]	1-147436-1
12.45	[.490]	1-147436-0
12.19	[.480]	147436-9
11.94	[.470]	147436-8
11.68	[.460]	147436-7
11.43	[.450]	147436-6
11.18	[.440]	147436-5
10.92	[.430]	147436-4
10.67	[.420]	147436-3
10.41	[.410]	147436-2
10.16	[.400]	147436-1

THIS DRAWING IS A CONTROLLED DOCUMENT.

DIMENSIONS: INCHES	TOLERANCES UNLESS OTHERWISE SPECIFIED:	0 PLC ± -	1 PLC ± -	2 PLC ± -	3 PLC ± 0.13(.005)	4 PLC ± -	ANGLES ± -
--------------------	--	-----------	-----------	-----------	--------------------	-----------	------------

APVD	23JUN00	DIN	HAYMAKER
CHK	4SEP98	DMN	M. CHIANG
NAME	.045 SQUARE CONTINUOUS POST, TIN		

APVD: M. CHIANG 4SEP98

SIZE	CAGE CODE	DRAWING NO.	RESTRICTED TO
A1	00779	147436	-

CUSTOMER DRAWING SCALE 10:1 SHEET 1 OF 1 REV C